



Introduction

Hygemax top-access cleanroom is the recessed ceiling lamp tray for indoor use. The manufacture process is extremely strict, high quality output with CE, ROHS certified.

Feature

- Housing material is made of >0.6mm thickness, high quality strength steel sheet which is painted with under go rust removal, grease removal, rustproof treatment and full spray-coated treatment in white.
- This range have a special design housing with top access function, suitable to the cleanroom with request of technical intervention are upper of ceiling.
- Optics has a bat-shape gloss aluminum louver reflector with or without I-grid design inside, cover by transparent PMMA sheet completes with rubber gasket to prevent dust ingress. This provides good glare control while delivering maximum lumens out of the luminaire.

Application area

- Applied to laboratories, hospitals, medical centres, etc.

Mounting type

- Recessed ceiling.

Approval and marking



Product color



Dimension: (mm)

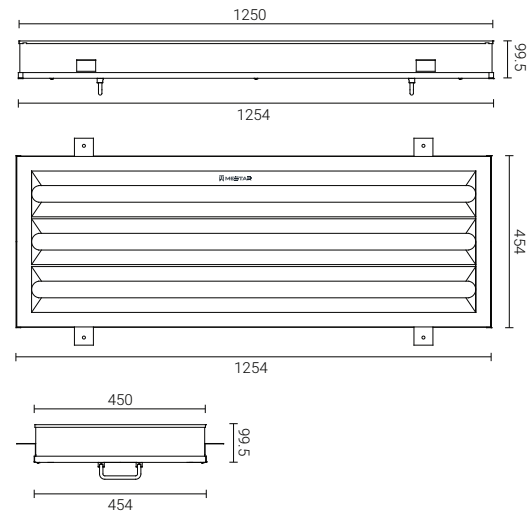

Technical information

• Model	: TSH018336-OB
• Number of lamp and rated power	: 3x20W (not include tube lamp)
• Input voltage	: dependent on tube lamp
• Others lighting specifications	: dependent on tube lamp
• Cover	: PMMA
• Protection grade	: IP54
• Product life	: >50000 hours

