

MODEL: MS1QR0102-1x3W

Introduction

Recessed LED stair light & wall is the recessed mounting luminaire for indoor/outdoor use. The manufacture process is extremely strict, high quality output with CE, ROHS certified. Its excellent light brings comfort and good experience to the users.

Feature

- Front cover & housing 12# die-casting aluminum anti-corrosion powder coating T=20-25 μ m, adhesion of ISO class 1/ ASTM class 4B high temperature painting.
- Light window glass.
- Power cable outside of luminaire H05RN-F 2x1.0mm², L=0.3m(DC24V), H05RN-F 3x1.0mm², L=0.3m (AC120/240V).
- LED driver constant voltage input, constant current output.
- Mounting sleeve PC/ABS alloys.
- Warranty 3 year.

Application area

- Applied to stairs, way, facade of building, hotel, resort and etc.

Mounting type

- Recessed mounting.

Approval and marking



Feature



Product color



Technical information

• Model	: MS1QR0102-1x3W
• Led chip	: LED COB OSRAM
• Rated power	: 1x3W
• Luminous flux	: 80lm (cool white), 72lm (warm white)
• Luminous efficacy	: 26.7lm/W (cool white), 24lm/W (cool white)
• Input voltage	: DC24V/AC120/240V 50/60Hz
• Color temperature	: 2700K/3000K/4000K/5700K/6500K
• Beam angle	: Asymmetric
• Control method	: On/off, Triac, PWM, 1-10V, Dali
• Protection grade	: IP65
• IK rating	: IK10
• Operating temperature	: -20°C~40°C
• Product life	: 35000 hours

We reserve the right to make technical and design changes.

THIEN MINH MECHANICAL - ELECTRIC JSC

Head office: MESTAR Building, No. 98/11 Ung Van Khiem Street, Ward 25, Binh Thanh District, Ho Chi Minh City, Vietnam

Tel: (84) 28.3899 4790 - Email: mestar@mestar.vn - Web: www.mestar.vn

Dimension: (mm)

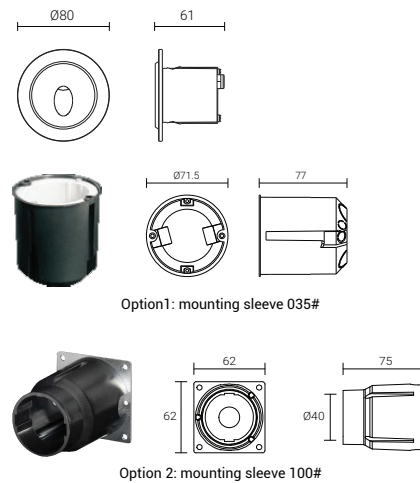

Photometric data

MS1QR0102-Asymmetric

