

# MAXI 2-FLOODLIGHTS AND PROJECTORS



### Introduction

MAXI 2 is powerful architectural floodlight series, adopt isolated two body structure design with separated dissipation to fully ensure the stability and long lifespan of LED light. With multi-way rotate function of U-support bracket to meet various occasions demands for outdoor projects.

### Features

- High pressure die-casting aluminum housing.
- High strength toughened glass.
- Inclined cover for anti-glare shield optional, honeycomb accessories for glare less application
- Surface finish with fluorine carbon spraying ensuring high corrosion resistance, resist the impact and friction.
- LED module: High-Power LEDs on metal-core PCB.
- High-efficiency PMMA lens with various beam angle option. Especially super-narrow 2.6° len for super spot application.
- Adopt American CREE original LED light source, high flux output, excellent consistency of color.
- Input power supply AC100-305V driver for both On/Off and DMX512/Bluetooth control method.
- Dynamic color with RGBW option have gray level reach 65,536 degree equally make the light result is more beautiful.
- Powerful DMX512 interface adopt high reliable bus connect, all has the function of automatic addressing.

### Applications areas

- Facade of outdoor buildings, billboards, area etc.

### Mounting type

- Surface mounting.

MODEL: **MS3HMA1278UR-150W**

### Approvals and markings



### Feature



### Beam angle

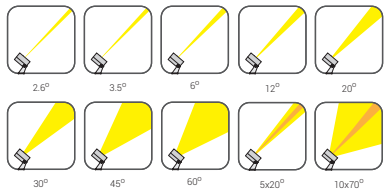

### Product color



### Dimension: (mm)

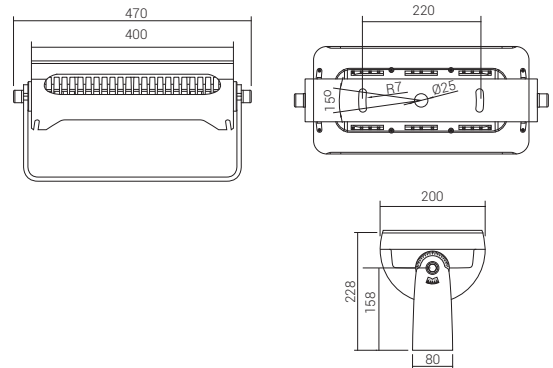

### Technical information

• Model	: MS3HMA1278UR-150W
• Led brand	: LUMILEDS/CREE
• Led quantity	: 36pcs
• Rated power	: 150W
• Lumen	: 6000lm ±10%
• Input voltage	: AC100-305V~ 50/60Hz
• Color temperature	: RGBW
• Beam angle	: 30°
• Control method	: DMX512
• Protection grade	: IP66
• Ambient temperature	: -25°C~50°C
• Ambient humidity	: 10%~90%
• Product life	: 80.000hrs

### Photometric Data

MS3HMA1278U-30°

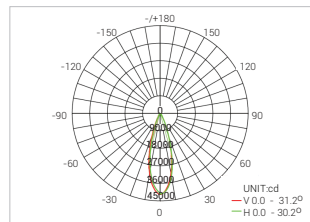

We reserve the right to make technical and design changes.

THIEN MINH MECHANICAL - ELECTRIC JSC

Head office: MESTAR Building, No. 98/11 Ung Van Khiem Street, Ward 25,

Binh Thanh District, Ho Chi Minh City, Vietnam

Tel: (84) 28.3899 4790 - Email: mestar@mestar.vn - Web: www.mestar.vn

Ha Noi Office: TT4.18, Xuan Phuong Tasco Urban Area, Xuan Phuong Ward,

Nam Tu Liem District, Hanoi City, Vietnam.

Tel: (84) 24.3222 2411



PROJECT DATA	Assigned code : .....
Project : .....	Location : .....
Approved by : .....	Date : .....

## Accessories

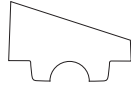

Inclined cover  
**MA-1278-AGS**

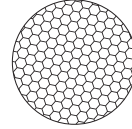

Honeycomb grill  
**MA-1278-HGR**

MS3HMA1278UR-150W	•	•
-------------------	---	---

## Connection Accessories



Connector 3 pin - IP68

**MA-M684-03**



T Connector 3 pin - IP68

**MA-M685T-03**



Y Connector - IP68

**MA-M685Y-03**



Junction box 3 holes - IP68

**MA-M686-03**

*We reserve the right to make technical and design changes.*

